

ElectroForce® 3100 Test Instrument

Performance and Durability in a Compact Package

Measuring less than 20 inches tall, the ElectroForce® 3100 test instrument is the smallest in the ElectroForce product family. Like all ElectroForce test instruments, the 3100 is extremely lab friendly thanks to its practically maintenance-free operation. With its compact size, whisper-quiet operation and energy-efficient design, the 3100 test instrument will fit on any tabletop and can be plugged into a standard wall outlet. Due to its exceptional control resolution, the 3100 test instrument is well-suited for:

- Tissue mechanics research
- Micro-indentation of cartilage and soft tissue
- Mechanical stimulation of tissue-engineered constructs
- Individual fiber testing
- BioMEMS evaluation and testing
- Durability testing of medical devices
- Dynamic Mechanical Analysis (DMA)

Example of Minimum Displacement and Force Control from the ElectroForce® 3100 Test Instrument

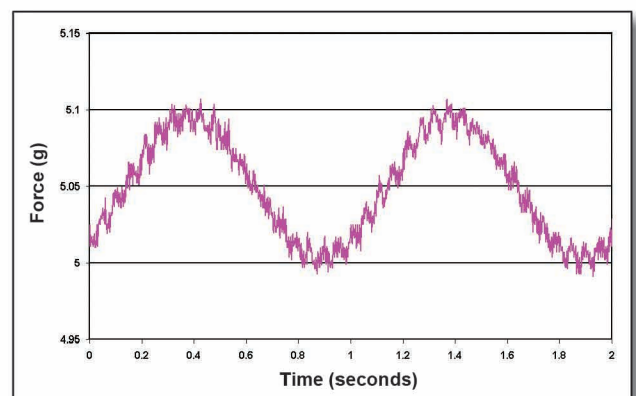
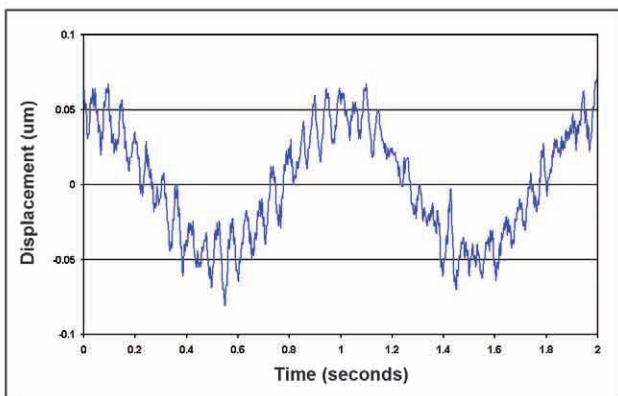

NOTE: Tests conducted with 50 g force and $\pm 50 \mu\text{m}$ displacement transducers to show system capability. These transducers are not included in the standard system configuration.



ElectroForce® 3100
Test Instrument

Bose® ElectroForce® Linear Motor

The ElectroForce 3100 instrument utilizes the performance and resolution of the ElectroForce linear motor. The proprietary motor utilizes a simple and durable moving-magnet design to achieve the proper performance for many low-force applications.

WinTest® PCI Control System

WinTest® PCI controls set the standard for dynamic mechanical fatigue testing. The WinTest software provides an intuitive interface that enables the user to efficiently set up tests. The software features a fully integrated display that simplifies test operation while providing advanced test capabilities. Data acquisition, waveform generation and instrument control are all provided within this comprehensive package.

ElectroForce® 3100 Test Instrument

Higher Resolution Transducers

The base configuration of the ElectroForce® 3100 test instrument provides 22 N of linear force with 20 G acceleration and frequency response to 100 Hz. The high resolution transducer configuration combines a 250 gram force transducer, and a 1.0 mm full scale ($\pm 500 \mu\text{m}$) displacement transducer, to enhance control resolution in force and displacement.

Accessories and Fixtures

Bose carries an extensive line of test equipment accessories including a wide range of grips and fixtures, transducers, environmental chambers and software options, such as Dynamic Mechanical Analysis. Contact Bose to discuss customized options for your ElectroForce 3100 test instrument.

Performance

Configuration Specifications

Maximum dynamic or static force capacity:	$\pm 22 \text{ N}$ (5 lb)
Minimum controllable peak-to-peak force:	6 mN (0.001 lb)
Minimum controllable peak-to-peak displacement:	0.0015 mm (0.00006 in)
Stroke:	5 mm (0.2 in)
Maximum frequency:	100 Hz

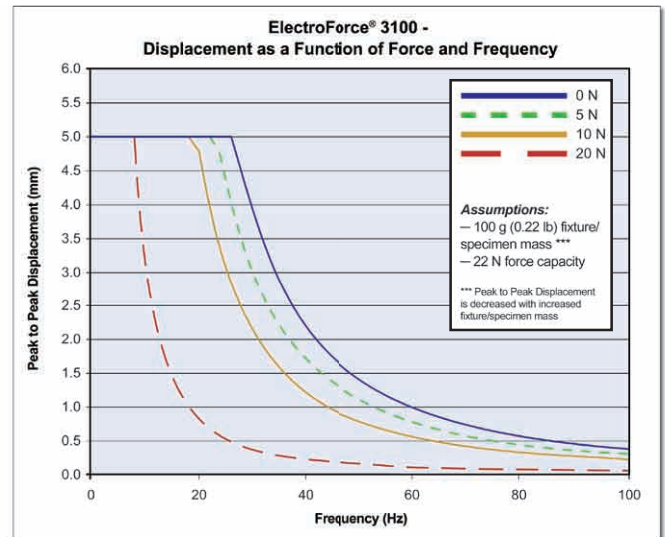

Specifications

Input Power:	115/230 VAC
Horizontal test space size:	178 mm (7.00 in)
Weight:	18 kg (40 lb)
Vertical test space size:	178 mm (7.00 in) (203 mm (8.00 in) without load cell)
Dimensions (H/W/D):	500 mm / 300 mm / 175 mm (19.38 in / 11.50 in / 7 in)

Other ElectroForce® instrument configurations are also available.

See our ElectroForce® and TestBench product brochures, or contact an applications engineer at 1-866-TESTING (1-866-837-8464) for more information.

Specifications are subject to change

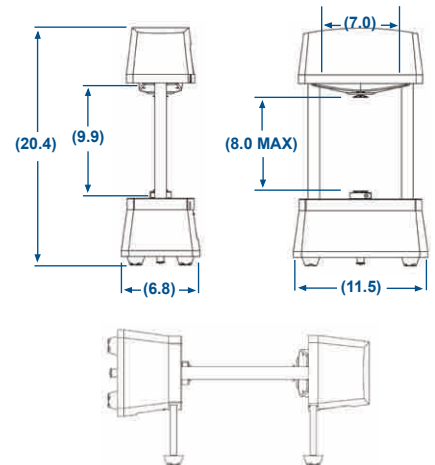

Optional horizontal and inverted configurations are available.